

Idler wheels

Part. 454 Split sprocket 10 teeth (for chains series 879, 879 TAB, 880, 880 TAB)

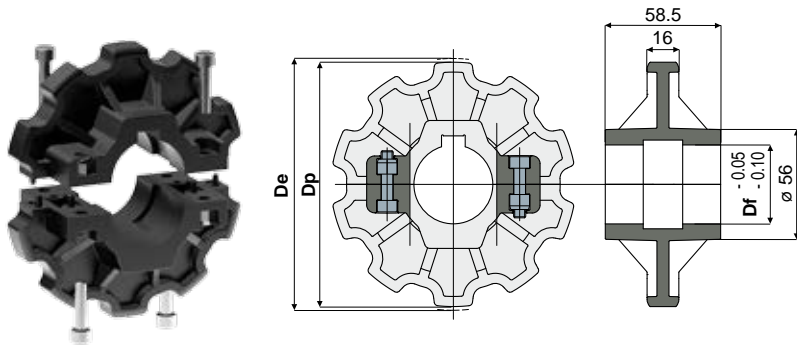

Df (mm)	Dp (mm)	De (mm)	Code
25	123,3	122,5	454 / 85416
30	123,3	122,5	454 / 85417
35	123,3	122,5	454 / 85418
40	123,3	122,5	454 / 85419

MATERIALS: Wheel made of reinforced polyamide black colour; screws made of stainless steel AISI 304, nuts in nickel plated brass.

FEATURES: Dimensions of the keyway UNI 6604-69 - DIN 6885/1. To be used with chains Part.710, 711, 713.

BOX QUANTITY: 8 pieces.

ON REQUEST:

- Wheels: In different colours.
- Box quantity: According to your request.

Part. 455 Split idler wheel 10 teeth (for chains series 879, 879 TAB, 880, 880 TAB)

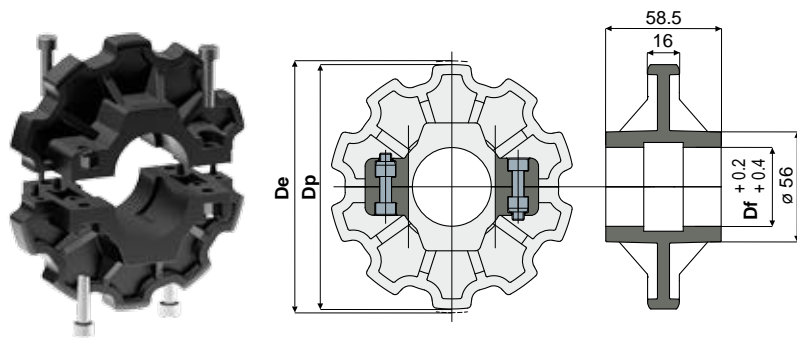

Df (mm)	Dp (mm)	De (mm)	Code
25	123,3	122,5	455 / 85420
30	123,3	122,5	455 / 85421
35	123,3	122,5	455 / 85422
40	123,3	122,5	455 / 85423

MATERIALS: Wheel made of polyamide black colour; screws made of stainless steel AISI 304, nuts in nickel plated brass.

FEATURES: To be used with chains Part.710, 711, 713.

BOX QUANTITY: 8 pieces.

ON REQUEST:

- Wheels: In different colours.
- Box quantity: According to your request.

Example of application

