

Threaded bushings

(for rectangular tubes)

Part. **82**

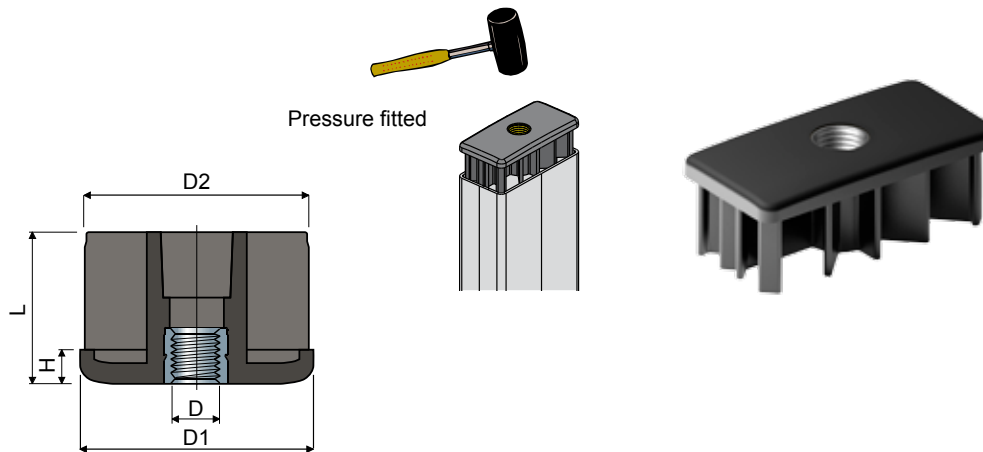

Tube dimensions								Code	Max static load (N)
Outside (mm)	Thickness (mm)	Inside (mm)	Thread D	D1 (mm)	D2 (mm)	H (mm)	L (mm)		
20x50	2	16x46	M8	20x50	16x46	5	27	82 / 80325	4500
30x60	2,5	25x55	M8	30x60	25x55	8	38	82 / 82173	4500
			M10	30x60	25x55	8	38	82 / 82175	5000
			M12	30x60	25x55	8	38	82 / 82176	5500
			M14	30x60	25x55	8	38	82 / 82177	6000
40x60	2	36x56	M16	30x60	25x55	8	38	82 / 82174	6500
			M14	40x60	36x56	10	45	82 / 85141	8500
			M16	40x60	36x56	10	45	82 / 84309	9000
40x80	1,5	37x77	M20	40x60	36x56	10	45	82 / 84311	9500
			M14	40x80	37x77	10	45	82 / 82973	8500
			M16	40x80	37x77	10	45	82 / 82975	9000
	2	36x76	M20	40x80	37x77	10	45	82 / 82977	9500
			M14	40x80	36x76	10	45	82 / 82180	8500
			M16	40x80	36x76	10	45	82 / 80326	9000
3	34x74	M20	40x80	36x76	10	45	82 / 80327	9500	
		M14	40x80	34x74	10	45	82 / 82590	8500	
		M16	40x80	34x74	10	45	82 / 82516	9000	
50x100	2	46x96	M20	40x80	34x74	10	45	82 / 82591	9500
			M14	50x100	46x96	10	45	82 / 82181	8500
			M16	50x100	46x96	10	45	82 / 80693	9000
	3	44x94	M20	50x100	46x96	10	45	82 / 80694	9500
			M14	50x100	44x94	10	45	82 / 82182	9000
			M16	50x100	44x94	10	45	82 / 82178	9500
50x150	3	44x144	M20	50x100	44x94	10	45	82 / 82179	10000
			M14	50x150	44x144	10	45	82 / 82183	9000
			M16	50x150	44x144	10	45	82 / 80211	9500
60x120	3	54x114	M20	50x150	44x144	10	45	82 / 80212	10000
			M14	60x120	54x114	10	45	82 / 82184	9000
			M16	60x120	54x114	10	45	82 / 80209	9500
			M20	60x120	54x114	10	45	82 / 80210	10000

Materials: Bushing in reinforced polyamide black colour; threaded insert in nickel plated brass.

Box quantity: 24 pieces.

On request

- **Bushings:** Can be supplied with thread in inches (1/4"-20, 5/16"-18, 3/8"-16, 1/2"-13, 5/8"-11, 3/4"-10, 1"-8, etc.); With different thicknesses and colours.
- **Box quantity:** According to your request.