

Idler wheels

Part. **589** **Split sprocket 10 teeth**
(machined, for chains series 882, 882 TAB)

NEW

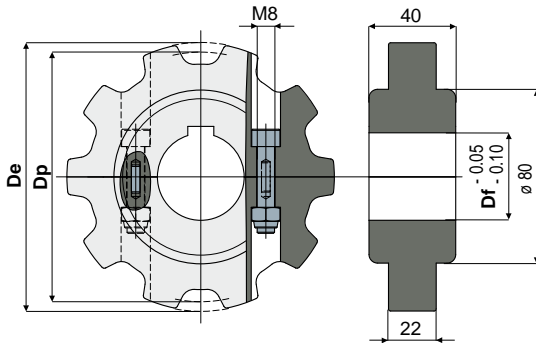

Df (mm)	Dp (mm)	De (mm)	Code
25	123,2	123,7	589 / 90985
30	123,2	123,7	589 / 90986
35	123,2	123,7	589 / 90987
40	123,2	123,7	589 / 90988

MATERIALS: Wheel made of polyamide blue Ral 5005 colour; screws made of stainless steel AISI 304, nuts in nickel plated brass.

FEATURES: Dimensions of the keyway UNI 6604-69 - DIN 6885/1.

BOX QUANTITY: 8 pieces.

ON REQUEST:

- Wheels: With 18 mm. hole diameter to be machined.
- Wheels: In polyamide blue Ral 5005 FDA APPROVED.
- Box quantity: According to your request.

Example of application

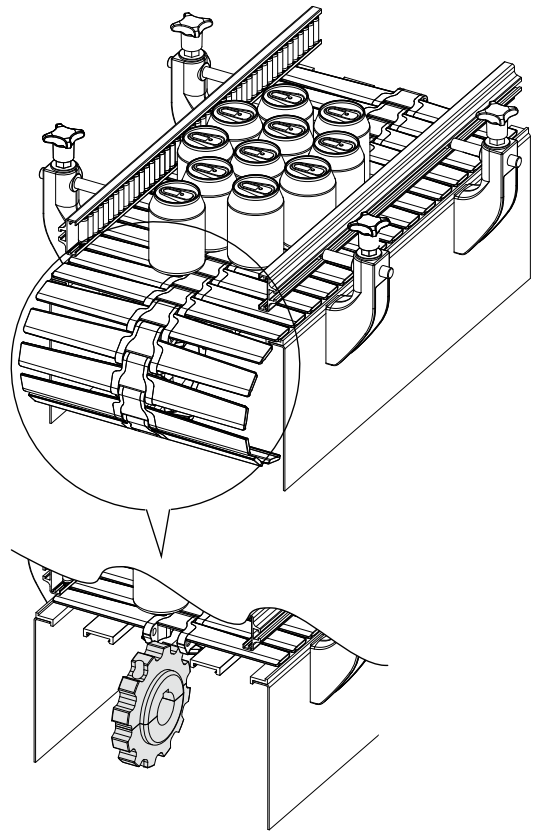

Part. **588** **Split idler wheel 10 teeth**
(machined, for chains series 882, 882 TAB)

NEW

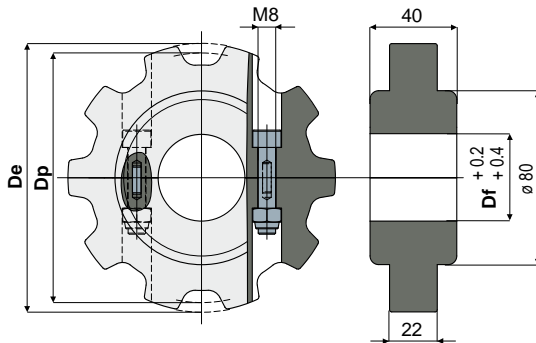

Df (mm)	Dp (mm)	De (mm)	Code
25	123,2	123,7	588 / 90981
30	123,2	123,7	588 / 90982
35	123,2	123,7	588 / 90983
40	123,2	123,7	588 / 90984

MATERIALS: Wheel made of polyamide blue Ral 5005 colour; screws made of stainless steel AISI 304, nuts in nickel plated brass.

BOX QUANTITY: 8 pieces.

ON REQUEST:

- Wheels: With 18 mm. hole diameter to be machined.
- Wheels: In polyamide blue Ral 5005 FDA APPROVED.
- Box quantity: According to your request.